

TRIPPLET



INSTRUCTION MANUAL

MODEL 850

ELECTRONIC VOLT-OHMMETER

MANUAL ONLY \$.50

Bought Jan. 23 - 1971

INSTRUCTION MANUAL

\$ 83.00

Belongs N. Di' Basso

153 E. Bourne Ave

Tiverton, R.I.

02878

From

J & S Electronics

Newport, R.I.



MODEL 850

ELECTRONIC VOLT-OHMMETER

ABOVE SERIAL 7000

THE TRIPLET ELECTRICAL INSTRUMENT CO.

BLUFFTON, OHIO

INSTRUCTION MANUAL



MODEL 850 ELECTRONIC VOLT-OHMMETER

ABOVE SERIAL 7000

THE TRIPLET ELECTRICAL INSTRUMENT CO.
BLUFFTON, OHIO

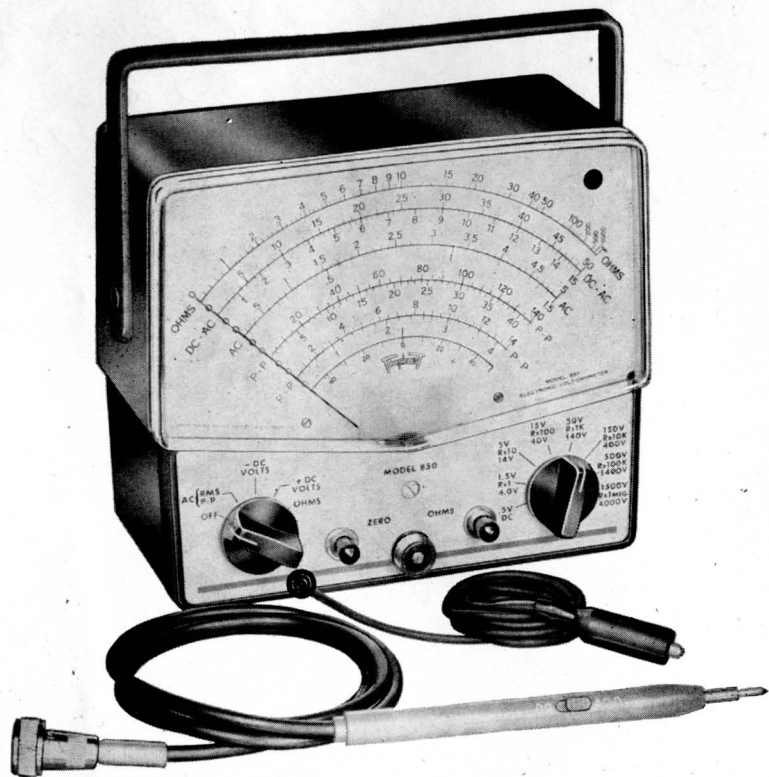

Model 850

TABLE OF CONTENTS

	Page
TECHNICAL DATA	4
GENERAL DESCRIPTION	5
PRELIMINARY ADJUSTMENTS	6
Installing Battery	6
Zeroing the Meter	6
Warm Up Period	6
DC Zero Adjustment	6
AC Balance Adjustment	7
OPERATING INSTRUCTIONS	8
General	
AC Voltage Measurements: RMS And Peak To Peak	8
AF Or Decibel Measurements	9
DC Voltage Measurements	9
Operation Chart	10-11
Resistance Measurements	12
Galvanometer Zero Center Scale	12
MAINTENANCE	13
DC Voltage Calibration	13
AC Voltage Calibration	15
Ohms Adjustment	15
Battery Replacement	16
Tube Replacement	16
Parts List	17
Schematic Diagram	18
WARRANTY	19

Power

117 Volts AC 50-60 cps; power consumption 6 Watts.

Ranges

DC Volts 0-.5-1.5-5-15-50-150-500-1500

AC Volts 0-1.5-5-15-50-150-500-1500

Peak to Peak 0-4-14-40-140-400-1400-4,000

Ohms 0-1000-10,000-100,000-1 Meg.-10 Meg. 100 Meg.-1000 Meg.

Frequency Range

15 CPS to 3 MC; up to 250 MC with accessory diode probe.

Input Impedance

DC Volts 11 Megohms—AC Volts minimum of .83 Megohm.

Meter

DC current for full scale deflection 200 μ a meter.

7 inch type with 7 inch scale length.

DC - AC RMS scale black on white.

Ohms scale black on white.

Peak to Peak scale red on white.

Accuracy

AC \pm 3%, DC \pm 3%

Tube Complement

1 — 12AU7, 1 — 6AL5.

Construction

Insulated black case; dimension outside $7\frac{5}{8}'' \times 6\frac{7}{16}'' \times 3\frac{3}{4}''$ with metal handle that can be used to place instrument on a 25° angle. Etched aluminum panel.

Weight

Approximately 5 pounds.

Accessories supplied with Model 850

1 DC/AC - OHMS probe and cable

1 Chassis ground lead

1 1.5 Volt battery

1 Alligator clip

1 Instruction book

Accessories Available

DC High Voltage probe 79B-196

RF probe 79A-215

Leather Carrying Case

GENERAL DESCRIPTION

The Electronic Volt-Ohmmeter is one of the most useful instruments in the electronic field, both in the laboratory and for service. Its high input impedance and wide frequency ranges give it considerable advantage over other types of voltmeters. The versatility of a Triplett Model 850 is greatly increased by the skill of the operator.

The 850 is an electronic voltmeter designed to measure DC voltages, resistance, AC RMS and peak to peak value. By adding color to the various ranges the meter dial is easy to read. Your 850 is designed with added protection for the highly sensitive meter. By special circuit arrangement the meter is shorted out in the OFF position for greater damping and meter safety during transit. The black molded case is completely insulated and has a plastic covered handle that can be used to place the instrument on a 25° angle.

The meter controls are clearly marked on an etched aluminum panel. All measurements are made on a seven-inch meter with separate red scales for peak to peak voltages.

One probe is used for all functions: DC, AC and OHMS. The small compact probe has a built-in sliding switch which places a one megohm resistor in series with the instrument on DC voltage readings. The 850 is frequency compensated up to 3 megacycles. Up to 250 MC can be measured with an RF probe obtainable on special order.

You will find four, black rubber feet inside of the envelope holding the probe. These feet are part of the tester, and are to be placed in the four holes at the rear of the case.

PRELIMINARY ADJUSTMENTS

The following procedure and adjustments should be made before using your Model 850. In following this procedure, you will familiarize yourself with the 850 and at the same time, increase the efficiency of the 850 and your use of it.

Installing Battery

1. Remove the five screws in the rear of the case, and pull the tester out of the case.
2. Install the battery (Eveready #935 or Burgess #1) observing the + polarity marking on the battery holder.

Zeroing the Meter

This is the mechanical adjustment of the meter, and is to be done with no power applied to the tester.

1. Place tester in vertical position.
2. Adjust the meter adjustment screw for exact zero meter indication.

Warm Up Period

1. Plug tester line cord into 117 a-c volt outlet and turn function switch to + D. C. Volts position.
2. Allow to warm up for 15 minutes.

D. C. Zero Adjustment

1. Connect probe cable to front panel connector, and place slide switch in DC position; connect the probe tip and long black ground lead together, which grounds the input of the VTVM.

2. Index the range switch to 1.5 volt position.
3. Adjust the front panel zero control (control to the left of the connector) until the meter is indicating exactly zero.
4. Turn the function switch to —D. C. Volts position. The meter reading should remain at exactly zero. If this is not true, repeat step Zeroing of the Meter above.

A. C. Balance Adjustment

1. If case is connected to panel, again remove the five screws from the back of the case and slide the panel approximately an inch out of the case. Note the row of calibration controls on top of the chassis, and that each control is plainly marked.
2. Tester must be on exact D. C. zero as mentioned in paragraph on Zero Adjustment.
3. Turn Function switch to A. C. Volts position. NOTE: Do NOT readjust the front panel zero control.
4. Place slide switch on probe to AC position, and probe is still to be shorted to the ground lead.
5. Note the A. C. Zero control, which is at one end of the row of controls inside the tester. This is the control closest to the neon lamp. Adjust this control until the pointer indicates exactly zero on the meter.
6. After this adjustment, changing from A. C. to D. C. volt indexes should not change the zero indication of the meter.

OPERATING INSTRUCTIONS

General

1. Connect DC/AC OHMS probe and cable to the front panel connector.
2. Plug the line cord into a 117 volt 60 cycle power outlet.
3. Check and adjust mechanical zero if necessary.
4. Turn function selector to DC VOLTS and allow at least 2 minutes to warm up.
5. Adjust electrical ZERO control to position on left hand zero on meter. Probe tip should be shorted to ground when adjusting electrical zero.
6. Turn function selector to OHMS position and adjust to full scale with OHMS control.
7. Red scale is for peak to peak readings—Black AC—DC—OHMS.
8. CAUTION: Do not use the common ground (black ground lead) in excess of 400 Volts AC, or 600 Volts DC from earth ground.
9. Tester is now ready for use.

AC Voltage Measurements: RMS and Peak to Peak

The probe switch should be in the AC-OHMS position for all AC voltage measurements. Peak to Peak voltage values are read from the red scales; RMS values are read from the black scales.

1. Set the function selector to AC.
2. Adjust the zero control to position the meter pointer at the left hand "0".
3. Select a higher voltage range than the voltage to be measured.
4. Connect the ground clip to ground (or the lowest potential of circuit under test.)
5. Connect the probe tip to the other side of the voltage.
6. Reset the range switch for a reading nearest full scale.

AF or Decibel Measurements

To measure decibels set the tester as above for AC Volts RMS. Convert the RMS readings to decibels with the chart below.

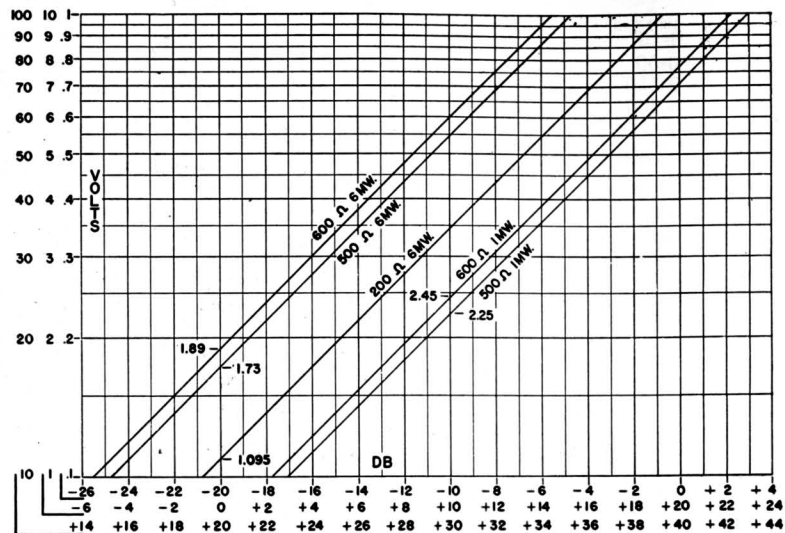

DC Voltage Measurements

On all DC voltage measurements the switch on the DC/AC OHMS probe should be in the DC position.

The probe is positive when the selector switch is in the +DC Volts position and negative when in the -DC Volts position.

1. Select the correct function; +DC Volts or -DC Volts.
2. Select a higher voltage range than the voltage to be measured.

(Continued on page 12)

TO MEASURE	SET RANGE SWITCH AT	SET FUNCTION SWITCH AT	PROBE SWITCH POSITION	READ ON SCALE	SCALE	REMARKS
DC Volts						
0-5	.5	DC VOLTS	DC	0-50 DC	÷ by 100	See instructions for DC Volts measurements. Be sure probe switch is in DC position.
0-1.5	1.5	DC VOLTS	DC	0-15 DC	÷ by 10	
0-5	5	DC VOLTS	DC	0-50 DC	÷ by 10	
0-15	15	DC VOLTS	DC	0-15 DC	Read Direct	
0-50	50	DC VOLTS	DC	0-50 DC	Read Direct	
0-150	150	DC VOLTS	DC	0-15 DC	x 10	
0-500	500	DC VOLTS	DC	0-50 DC	x 10	
0-1500	1500	DC VOLTS	DC	0-15 DC	x 100	
AC-RMS						
0-1.5	1.5	AC - RMS	AC - OHMS	0-1.5 AC	Direct	See instructions for AC RMS measurements.
0-5	5	AC - RMS	AC - OHMS	0-5 AC	Direct	
0-15	15	AC - RMS	AC - OHMS	0-15 AC	Direct	
0-50	50	AC - RMS	AC - OHMS	0-50 AC	Direct	
0-150	150	AC - RMS	AC - OHMS	0-15 AC	x 10	
0-500	500	AC - RMS	AC - OHMS	0-50 AC	x 10	
0-1500	1500	AC - RMS	AC - OHMS	0-15 AC	x 100	
OHMS						
0-1000	R x 1	OHMS	AC - OHMS	0-1000 OHMS	Read Direct	See instructions for resistance measurements. Be sure probe switch is in OHM position.
0-10,000	R x 10	OHMS	AC - OHMS	0-1000 OHMS	x 10	
0-100,000	R x 100	OHMS	AC - OHMS	0-1000 OHMS	x 100	
0-1,000,000	R x 1K	OHMS	AC - OHMS	0-1000 OHMS	x 1K	
0-10,000,000	R x 10K	OHMS	AC - OHMS	0-1000 OHMS	x 10K	
0-100 Meg.	R x 100K	OHMS	AC - OHMS	0-1000 OHMS	x 100K	
0-1000 Meg.	R x 1 Meg.	OHMS	AC - OHMS	0-1000 OHMS	x 1 Meg.	
Peak to Peak						
0-4	4	AC - PP	AC - OHMS	0-4 PP	Read Direct	See instructions for Peak to Peak voltage measurement.
0-14	14	AC - PP	AC - OHMS	0-14 PP	Read Direct	
0-40	40	AC - PP	AC - OHMS	0-40 PP	Read Direct	
0-140	140	AC - PP	AC - OHMS	0-140 PP	Read Direct	
0-400	400	AC - PP	AC - OHMS	0-40 PP	x 10	
0-1400	1400	AC - PP	AC - OHMS	0-140 PP	x 10	
0-4000	4000	AC - PP	AC - OHMS	0-40 PP	x 100	
Decibels						
See Chart -26 to +40	1.5	AC - RMS	AC - OHMS	Black AC Scales		See instructions for Decibel measurements.
	5	AC - RMS	AC - OHMS			
	15	AC - RMS	AC - OHMS			
	50	AC - RMS	AC - OHMS			
	150	AC - RMS	AC - OHMS			

3. Connect the ground clip to ground (or the lowest potential of circuit under test.)
4. Connect the probe tip to the high side of the voltage to be measured.
5. Set the range switch to the position that gives a reading nearest full scale.
6. The DC voltage is then read on the scale corresponding to the range setting.

Resistance Measurements

The probe switch should be in the AC OHMS position when resistance measurements are made. Power must be removed from equipment under test before resistance measurements are made.

1. Set function switch to the OHMS position.
2. Set range switch to the Rx10 position.
3. Short the probe tip to the ground cable and adjust the ZERO control to position the pointer at the left-hand "0".
4. Separate the probe tip from the ground cable. Adjust the meter pointer to full scale with the OHMS control.
5. Connect the ground cable clip to one side of the resistance to be measured.
6. Connect the probe tip to the other side of the resistance to be measured.
7. Reset the range control to give a convenient deflection on the OHMS scale.
8. After resetting the range control repeat steps three and four.
9. Multiply the reading on the OHMS scale by the range switch setting.

Galvanometer Zero Center Scale

Zero center scale is available for lining up the discriminator in FM circuits or for other Galvanometer readings.

To use the Zero Center Scale as a Galvanometer:

1. Set the function switch to "+DC Volts".
2. Adjust the ZERO control to position the pointer at the "-0+" which is at the bottom of the meter scale.
3. Set the range selector to a position at least twice the voltage to be measured.
4. Full scale readings will be half the value of the range setting since "0" is in center of the meter.

Example: If range switch is on 5 DCV and "0" is in center of meter, the meter will read -2.5, 0, +2.5 Volts.

MAINTENANCE

DC Voltage Calibration

1. Zero the mechanical meter zero.
2. Set on +DC Volts position and allow 15 minutes minimum warm up.
3. Line voltage should be 117 Volts 60 CPS.
4. Zero the electrical zero.
5. Set on 50 Volt position.
6. Set the probe switch on DC position.
7. Connect ground lead of 850 to negative side of 50 Volt DC standard source. Connect positive side of source to probe tip.
8. Adjust the +DC cal. potentiometer so the meter reads exactly 50 Volts full scale.
9. Reverse the test lead connections at the voltage sources.
10. Set switch to -DC Volts.
11. Adjust the -DC cal. potentiometer so the meter reads exactly 50 Volts full scale.
12. Check the remaining DC voltage ranges with a standard voltage source.

13. Index Range switch to .5 DC position, and turn Function switch to + DC Volts.
14. Connect probe lead and ground leads together and zero tester.
15. Connect leads across a standard .5 DC voltage supply, and adjust pointer to a full scale reading by means of the control marked + .5 and located in the row of controls on the chassis.
16. Disconnect leads, turn Function switch to — DC volts, and connect leads to standard .5 DC voltage supply, connecting the leads in just the opposite manner than in step 15 above.
17. Adjust the — .5 control on the chassis until the pointer is on the full scale mark on the meter.

AC Voltage Calibration

1. Set the probe switch to the AC/OHMS position.
2. Set on AC Volt position.
3. Set on 1.5 Volt range.
4. Short the probe tip to ground and adjust the AC Zero potentiometer so the meter reads exactly zero. If zero cannot be obtained, replace the 6AL5 tube. (Use only RCA or Sylvania).
5. Set on the 50 Volt range.
6. Apply 50 Volts 60 CPS to the probe tip and ground lead.
7. Adjust the AC cal. control so the meter reads exactly 50 Volts full scale.
8. Check the remaining AC voltage ranges with a standard voltage source.

Ohms Adjustment

1. Set the 850 to the +DC Volts position and zero if necessary.
2. Set to OHMS position.
3. Set to R x 1 range.
4. Adjust OHMS control for full scale.

NOTE: In areas where the line voltage is not 117 Volts, it may be desirable to readjust the AC Zero potentiometer so that the DC and AC ranges automatically balance at the same point. To do this:

1. Set on DC+ position and allow 15 minutes to warm up.
2. Set probe to DC, short probe to ground, and adjust to zero with electrical zero control.
3. Set probe to AC/OHMS position.
4. Set selector on AC Volt position.
5. Short probe to ground. Do not move electrical zero. Adjust to zero by means of the AC Zero potentiometer, which is the control nearest the neon light, on the inside of the tester.

Battery Replacement

The 1.5 Volt battery is used for resistance measurements only. If unable to adjust pointer to full scale on the R x 1 range, the battery should be replaced with Eveready #935, Burgess #1 or equivalent.

Tube Replacement

Should it become necessary to replace a tube, the following procedure should be followed. The tubes in the Model 850 have been aged and selected before being put into use. Select a 12AU7 tube that after a 15 minute warm up period is fairly stable when switching from one DC range to another. After tube selection it should be aged in the 850 for 100 hours. Sometimes it is possible that a tube will prove unstable after being aged. In such case the procedure must be repeated.

When replacing the 6AL5 it is only necessary to age it 100 hours in the 850 with the power turned on. This should be replaced by only RCA or Sylvania 6AL5 tubes.

When replacing either or both tubes it is necessary for the calibration to be checked as outlined in the DC voltage calibration and AC voltage calibration procedure under maintenance.

We recommend that all major recalibrating and repairs be done by the manufacturer. Our meter maintenance department is at your service. When necessary to return your instrument for repair, please write for return authorization.

REQ.	DESCRIPTION	TRIPLETT PART NO.
—	Lead Assem. 850 Chassis Ground	79A-214
B1	Lead Assem. 850 Probe	79B-192
P1	Battery, 1.5 volts Eveready 935 or equal	T-2426-2
T1	Power Cord	T-2566A-51
L1	Transformer	23A-175
L1	Neon Lamp, NE-2H	67-98
X1	Rectifier, ERIE ED3003	T-2250-55
J1	Jack	T-3238-1
V1	Tube 6AL5	T-2600-6AL5
V2	Tube 12AU7	T-2600-12AU7
—	Knobs, Switch	34-48
C2	Capacitor, Dry Electrolytic 12 mfd., 250V	43-242
C3	Capacitor, Tubular .1 mfd., $\pm 20\%$, 1000V	43-235
C5 & C7	Capacitor, Tubular .05 mfd., $\pm 20\%$, 400V	T-43-37
C1, C4 & C8	Capacitor, Ceramic Disc, 0.01 mfd., 500 WVDC	43-198
S1	Switch, Function	22A-391
S1	Switch Assembly with Resistor Function	22-436
S2	Switch Selector	22A-390
S2	Switch Assembly with Resistor Selector	22-437
R1	Resistor, 10K ohm $\pm 1\%$, $\frac{1}{2}$ watt, Film Type	T-15-2921
R2	Resistor, 20K ohm $\pm 1\%$, $\frac{1}{2}$ watt, Film Type	T-15-3202
R3	Resistor, 70K ohm $\pm 1\%$, $\frac{1}{2}$ watt, Film Type	15-3302
R4	Resistor, 200K ohm $\pm 1\%$, $\frac{1}{2}$ watt, Film Type	15-2931
R5	Resistor, 700K ohm $\pm 1\%$, $\frac{1}{2}$ watt, Film Type	15-3303
R6	Resistor, 2 Meg. ohm $\pm 1\%$, $\frac{1}{2}$ watt, Film Type	T-15-3390
R7	Resistor, 7 Meg. ohm $\pm 1\%$, $\frac{1}{2}$ watt, Film Type	15-3296
R8	Resistor, 3.3 Meg ohm $\pm 10\%$, $\frac{1}{2}$ watt, Composition	T-15-2474
R9, R11	Resistor, 10K ohm $\pm 20\%$, $\frac{1}{4}$ watt, Variable	16-131
R12	Resistor, 750 ohm $\pm 20\%$, $\frac{1}{4}$ watt, Variable	16-141
R13 & R14	Resistor, 33K ohm $\pm 10\%$, $\frac{1}{2}$ watt, Composition	15-2507
R15	Resistor, 510 ohm $\pm 5\%$, $\frac{1}{2}$ watt, Composition	15-217
R16	Resistor, 15K ohm $\pm 5\%$, $\frac{1}{2}$ watt, Composition	T-15-1873
R17	Resistor, 500 ohm $\pm 20\%$, $\frac{1}{4}$ watt, Variable	16-133
R18	Resistor, 3.6K ohm $\pm 5\%$, $\frac{1}{2}$ watt, Composition	15-1456
R19, R20	Resistor, 27K ohm $\pm 5\%$, $\frac{1}{2}$ watt, Composition	15-1737
R21	Resistor, 30K ohm $\pm 5\%$, $\frac{1}{2}$ watt, Composition	15-1115
R22	Resistor, 4K ohm $\pm 20\%$, $\frac{1}{4}$ watt, Variable	16-147
R10, R24	Resistor, 5.1K ohm $\pm 5\%$, $\frac{1}{2}$ watt, Composition	15-1411
R23	Resistor, 150K ohm $\pm 1\%$, $\frac{1}{2}$ watt, Film Type	15-2925
R25	Resistor, 324K ohm $\pm 1\%$, 1 watt, Film Type	15-3304
R26	Resistor, 900K ohm $\pm 1\%$, 2 watt, Film Type	15-3305
R27	Resistor, 10 meg ohm $\pm 5\%$, $\frac{1}{2}$ watt, Composition	15-3298
R28	Resistor, 1 meg ohm $\pm 5\%$, $\frac{1}{2}$ watt, Composition	15-824
R29	Resistor, 100K ohm $\pm 5\%$, $\frac{1}{2}$ watt, Composition	6524
R30	Resistor, 10K ohm $\pm 5\%$, $\frac{1}{2}$ watt, Composition	15-1482
R31	Resistor, 1K ohm $\pm 5\%$, $\frac{1}{2}$ watt, Composition	3711
R32	Resistor, 100 ohm $\pm 5\%$, $\frac{1}{2}$ watt, Composition	T-2601- $\frac{1}{2}$ -100
R33	Resistor, 9.3 ohm $\pm 1\%$, Wirewound	15-3639
R34	Resistor, 100K ohm $\pm 1\%$, $\frac{1}{2}$ watt, Film Type	15-2930
R35	Resistor, 201K ohm $\pm 1\%$, $\frac{1}{2}$ watt, Film Type	15-3388
R36	Resistor, 720K ohm $\pm 1\%$, $\frac{1}{2}$ watt, Film Type	15-3389
R37	Resistor, 2.12 meg ohm $\pm 1\%$, $\frac{1}{2}$ watt, Film Type	15-3391
R38	Resistor, 8.49 meg ohm $\pm 1\%$, 1 watt, Film Type	15-3301
R39	Resistor, 18.9 meg ohm $\pm 1\%$, 2 watt, Film Type	15-3307
R40	Resistor, 1.5 meg ohm $\pm 5\%$, $\frac{1}{2}$ watt, Composition	15-3297
R41	Case Assem.	10A-1796
	Front Assem., Instrument	10A-1795

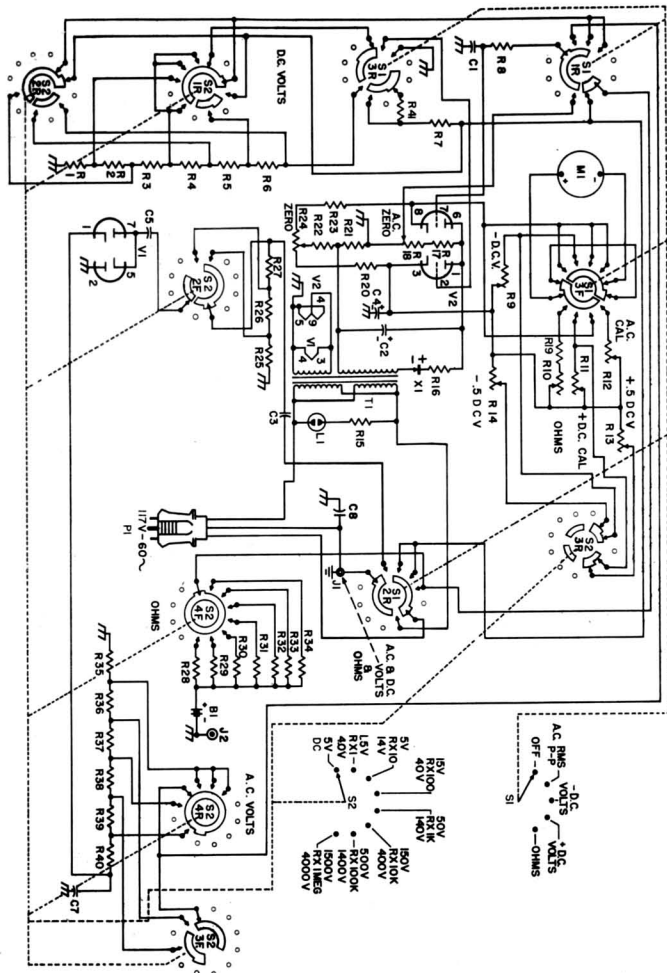

TRIPLETT WARRANTY AND CONDITIONS OF SALE

The Triplett Electrical Instrument Company warrants instruments manufactured by it to be free from defective material or factory workmanship and agrees to repair or replace such instruments which under normal use and service, disclose the defect to be the fault of our manufacturing. Our obligation under this warranty is limited to repairing or replacing any instrument or test equipment which proves to be defective, when returned to us transportation prepaid, within ninety (90) days from the date of original purchase.

This warranty does not apply to any of our products which have been repaired or altered by unauthorized persons or service stations in any way so as, in our judgment, to injure their stability or reliability or which have been subject to misuse, negligence, or accident, or which have had the serial number altered, effaced, or removed. Neither does this warranty apply to any of our products which have been connected, installed, or adjusted otherwise than in accordance with the instructions furnished by us. Accessories including all vacuum tubes and batteries not of our manufacture used with this product are not covered by this warranty.

The Triplett Electrical Instrument Company reserves the right to discontinue models at any time, or change specifications or design, without notice and without incurring any obligation.

Upon acceptance of the material covered by this invoice the purchaser agrees to assume all liability for any damages and bodily injury which may result from the use or misuse of the material by the purchaser, his employees, or others, and that The Triplett Electrical Instrument Company shall incur no liability for direct or consequential damage of any kind.

Parts will be made available for a maximum period of five (5) years after the manufacture of this equipment has been discontinued. Parts include all materials, charts, instructions,

diagrams, accessories, et cetera, which were furnished in the standard or special models.

This warranty and conditions of sale are in lieu of all others expressed or implied and no representative or person is authorized to assume for us any other liability in connection with the sale of our products.

THE TRIPLETT ELECTRICAL INSTRUMENT COMPANY

Bluffton, Ohio

Printed in U.S.A.

Part No. 84-112-072467-21

